



P.A. - S.r.l. - EQUIPAGGIAMENTI TECNICI DEL LAVAGGIO

VIA MILANO, 13 - 42048 RUBIERA (REGGIO EMILIA) - ITALY - Tel. +39 0522 623611 (10 linee)
 Fax +39 0522 629600 - R.E.A. RE 156319 - Registro Imprese RE 11535 - Mecc. RE 013446
 C.F. e P.IVA 01035950359 - Cap. Soc. i.v. € 750.000,00 - Codice Identificativo C.E.E. IT 01035950359
 ART. 2497 - BIS C.C. DIREZIONE E COORDINAMENTO BENETTI srl R.I. TRIB. DI RE 01480690351
<http://www.pa-etl.it> - E-mail: info@pa-etl.it



RL37 - Weeping – Spray gun 310 bar – 31 MPa

Technical manual : **E 118**

Guns suitable for use up to 310 bar – 31 MPa rated pressure pumps.
 Always leaks a small quantity of fluid.

DN10



- **30.1210.00** RL37 Weeping G3/8 G1/4 FF
- **30.1215.00** RL37 Weeping + SW6 G3/8 G1/4 FF

- Covered by shockproof plastic semi-housings.
- Weeping seat and Sst ball.
- Internal structure in brass and Sst.
- Ergonomic construction.
- Minimum fatigue for trigger opening and use.

TECHNICAL SPECIFICATIONS

Maximum temperature 160°C (1)

P/N	RATED PRESSURE bar - MPa	PERMISSIBLE PRESSURE bar - MPa	MAX FLOW RATE l/min	WEeping WITH PRESSURE 2.8 bar – 0.3 MPa l/min	INLET OUTLET	WEIGHT gr
30.1210.00	310 - 31	350 - 35	40	1.1 ÷ 1.3	G3/8 G1/4 FF	573
30.1215.00	310 - 31	350 - 35	40	1.1 ÷ 1.3	G3/8 G1/4 FF	626

((1)) The gun has been designed for continuous use, at a water temperature of 90°C (195°F). It can resist at the max temperature of 160°C (320°F) for short periods only, as, when the gun shuts off, the heater continues to transmit the heat to the water, thus increasing both temperature and pressure up to high, dangerous values.

Using the gun at a water temperature higher than 60°C involves for the operator the use of adequate safety devices, such as gloves, glasses, etc.

Instruction manual, maintenance, installation, spare parts.
 For a correct utilization, follow the directions of this manual
Re-print them on the Use and Maintenance booklet of the machine.

n. 12.9118.00

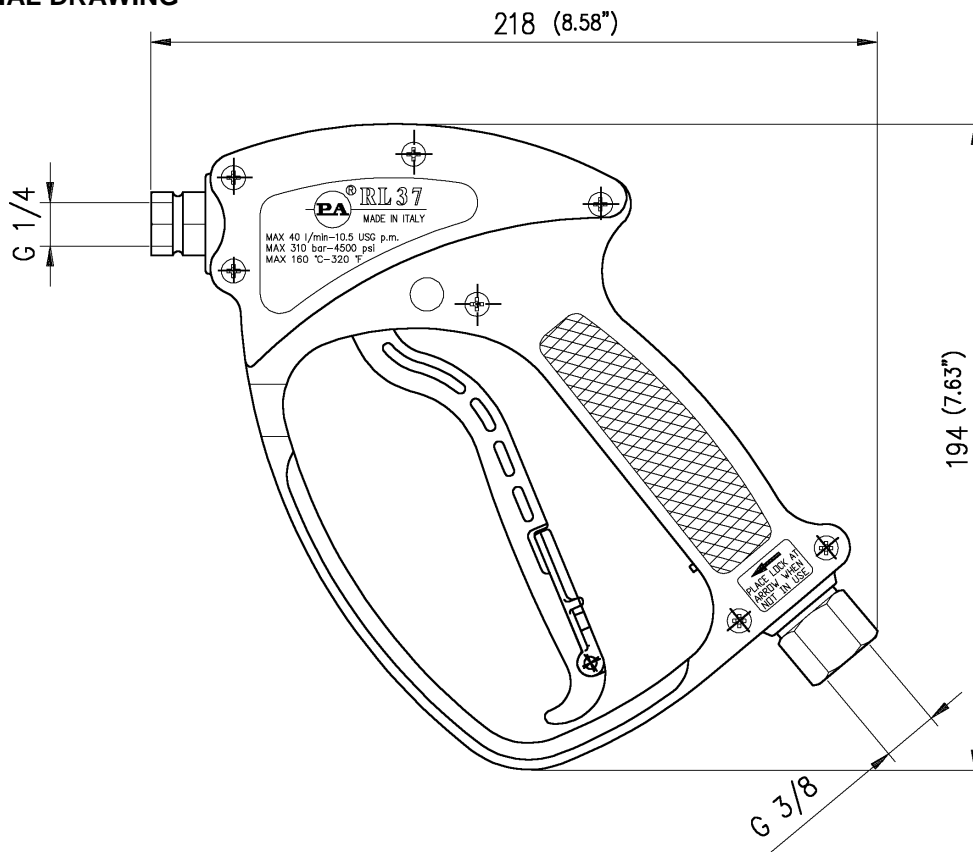
DIMENSIONAL DRAWING**INSTRUCTIONS**

This product is to be utilized with clean fresh water, even slightly additivated with normal detergents. For use involving different or corrosive liquids, contact the PA Technical department. Appropriate filtration should be installed when using unclean liquids. Choose the gun in line with the data of nominal running (system rated pressure, max flow and max temperature). In any case, the pressure of the machine should not exceed the permissible pressure rate imprinted on the gun.

INSTALLATION

This gun was designed to operate with **hot water** (in compliance with the technical specs). Provide the plant generating **hot water** with an equipment limiting the incidental increase of the fluid temperature.

Always fit a safety valve to protect the delivery conduct when the latter is under pressure.

Choose a suitable nozzle and adjust the valve mounted in the front of the gun, thus obtaining a constant supply and avoiding unpleasant pressure spike when closing the system.

If the nozzle wears out, the pressure falls. When you install a new nozzle, adjust the system back to the original pressure.

OPERATIONS

The gun opens and closes a high pressure conduct by means of a piston acting on a seat; the return is controlled by a spring which releases the trigger. **Attention: during pump activation always set the gun with its safety latch connected in order to prevent accidental openings.**

WATER HOSE FEED

By high or very unsteady pressure values on delivery, it is necessary to mount a pressure reducer, both to level the flow rate on delivery and to protect the system components.

PROBLEMS AND SOLUTIONS

PROBLEMS	PROBABLE CAUSES	SOLUTIONS
Excessive fluid loss	Seat and ball worn out Solid slag pollution	replace fit adequate filters
Leaking seals	Seals worn out	Replace seal
Difficult trigger opening	High pressure inside circuit	Control the bypass valve and adjust if necessary

REGULATIONS

The design and construction of our products comply with: norm CEI EN 60335-2-79 first edition, published in 1999-03 and its respective variations on the project norm prEN 1829.

Read this manual before starting the assembly.

For a correct utilization, follow the directions described in this manual and re-print them on the Use and maintenance manual of the machine.

The present manual is valid for all the guns named **RL37 Weeping.**

SPARES

Use original PA spares only in order to get both a correct operation and a long lasting, reliable product.

MAINTENANCE

Maintenance has to be carried out by **Specialized Technicians.**

STANDARD: every 400 working hours (circa 10,000 cycles), check and lubricate the seals with water resistant grease.

SPECIAL: every 800 working hours(circa 20,000 cycles), check the wear of the seals and internal parts and if necessary, replace with original PA parts, taking care during installation to lubricate with water resistant grease.

CAUTION: re-assemble the gun restoring the original conditions.

The manufacturer is not to be considered responsible for damage as a result from incorrect fitting and maintenance.

Technical data, descriptions and illustrations are indicative and liable to modification without notice.

30.1200.00 RL37 spr.gun 3/8F-1/4F Bsp
 30.1200.50 RL37 spr.gun 3/8F-1/4F Npt
 30.1200.80 RL37 gun -3/8-1/4Bsp MF

30.1210.00 RL37 weep gun -3/8-1/4Bsp FF
 30.1215.00 RL37 weep gun+sw6 -Bsp3/8F x 1/4F
 30.1220.00 RL37 spr.gun +sw.6 3/8F-1/4F Bsp

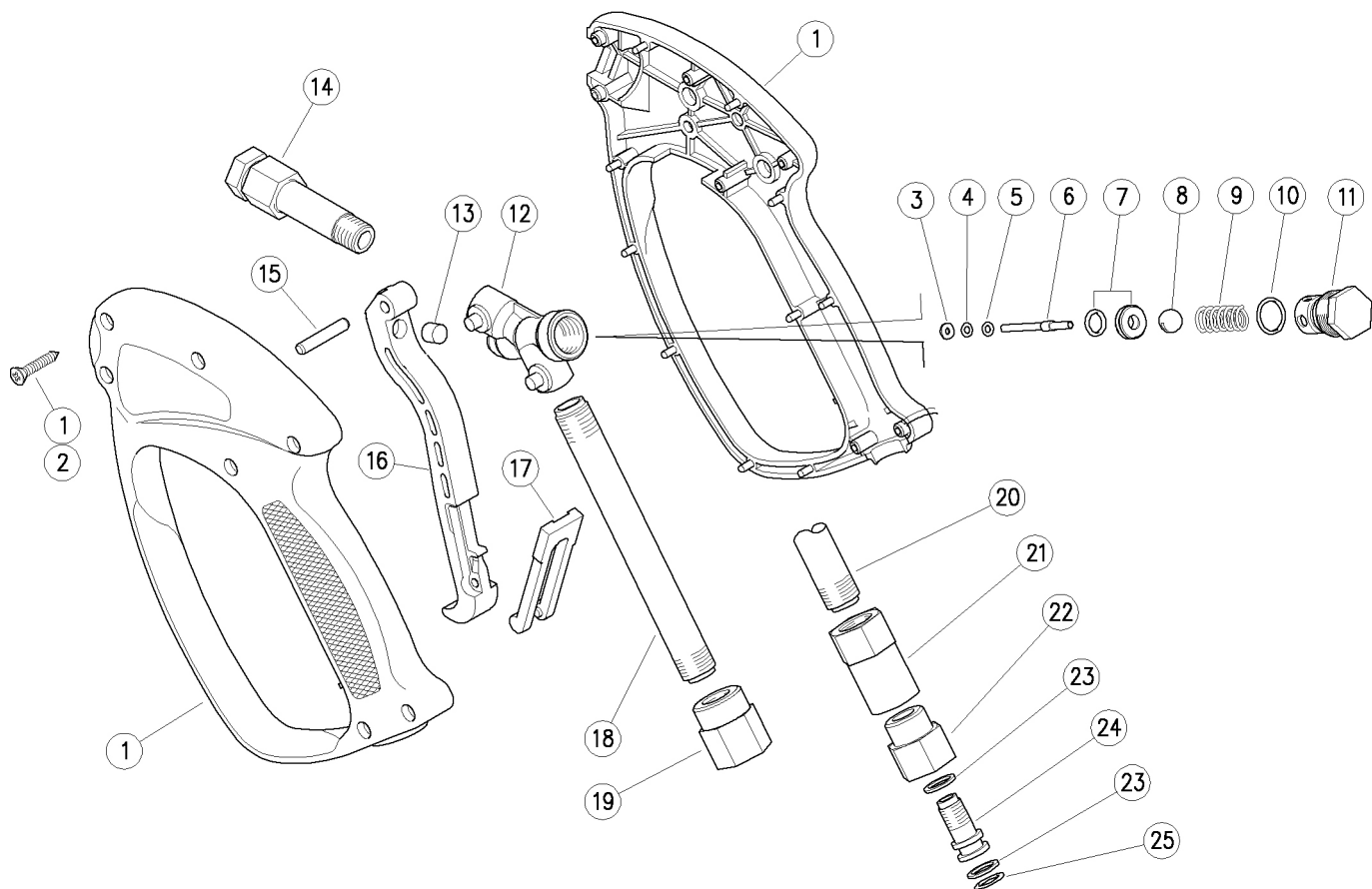

Pos.	P/N	Description	Q.ty	K1	K2	K3	K4	
1	30.1207.24	Casing-kit -RL37 +screws, Sst.	1					1
2	16.3077.00	S/tapping screw, DIN7981 3,5x18 mm	7					10
2	16.3075.51	S/tapping screw, DIN7981 3,5x18 mm Sst. (1)	7					10
3	10.4018.00	Back-up ring, 3,2x7,5x1,2 mm	1	•	•			10
4	10.3165.00	O-ring, 2,62x2,84 mm Vi 70	1	•	•			10
5	14.3511.00	Washer, 3,2x7x0,5 mm sst.	1	•	•			10
6	30.0704.51	Piston, 3-4 mm Sst.	1	•	•			10
7	30.1708.20	Seat, 6mm Sst.+O-ring 1,78mm NBR85	1	•	•			10
7	30.0716.20	Weep.seat,5,8mm+O-ring (l.1,1) (1)	1					10
8	14.7448.00	Ball, 5/16" Sst.	1	•	•			10
9	30.2596.51	Spring, 1,5x6,1x24 mm Sst.	1					10
10	10.3020.02	O-ring, 1,5x10 mm Ni 85	1	•	•			10
11	30.2595.31	Spring plug, M16x1 brass	1					10
12	30.1205.35	Housing -RL37, brass	1					5
13	30.0675.84	Stop pin, 8x7,1mm PA	1					10
14	30.2006.35	Front tube, 1/4F Bsp 72 mm brass	1					5
14	30.2008.35	Front tube, 1/4F Npt 72 mm brass (2)	1					10
15	30.2517.31	Parallel pin, 5x27,5 mm brass	1					10
16	30.1204.84	Trigger -RL37, PA black	1					10
17	30.1510.84	Safety latch, PA red	1					10
17	30.1515.84	Safety latch, PA blue (1)	1					10
18	30.1203.66	Tube, 1/4Bsp MM 140 mm z.pl.	1					5
19	30.1206.31	Coupl., 1/4F-3/8F Bsp brass (3)	1					5
19	30.1208.31	Coupl., 1/4F Bsp-3/8F Npt brass (2)	1					5
19	30.1212.31	Adapter, 1/4F-3/8M Bsp brass (4)	1					5
20	30.1221.66	Tube, 1/4Bsp MM 115 mm z.pl. (5)	1					5
21	30.1222.31	Adapt., M10x1F-1/4F Bsp brass (5)	1					5
22	30.2019.31	Coupl., 3/8F Bsp brass (5)	1					5
23	10.4010.01	Back-up ring, opn. 10,2x13,9x1,2 mm (5)	2	•				50
24	30.2017.51	Pin, SW M10x1 M Sst. (5)	1					5
25	10.3109.95	O-ring, 2,4x9,3 mm Vi 70 (5)	1	•				25

Kit	P/N	Description	Q.ty
K1	30.1209.24	Repair kit -RL37, 8x1pcs.	1
K2	30.1224.24	Repair kit -RL37+sw6 10x1pcs.	1

(1) 30.1210.00 (2) 30.1200.50 (3) 30.1200.00 (4) 30.1200.80 (5) 30.1220.00